

TMCRS



Tube Mill Central Recovery System

OPERATION

The TMCRS was developed for tube mill facilities to remove contaminants from tube mill coolant.

The TMCRS is furnished in start up condition with minor assembly and requiring only electrical connection and city water for coolant proportioner.

The TMCRS is manufactured from mild coated steel and other high-grade material suited for industrial applications.

Total Effectiveness

- Reduces waste disposal costs
- Reduces new fluid purchases
- Quick system payback
- Easy to operate

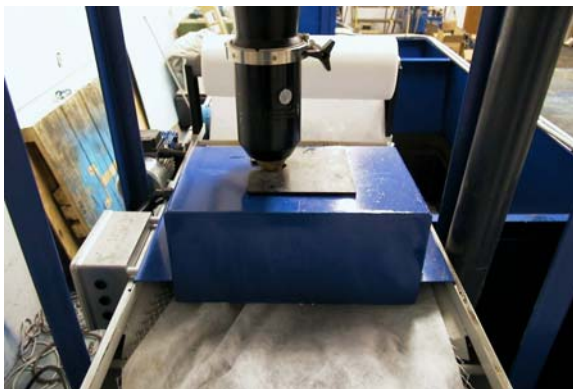

Economical, Field Proven Performance

- Removes tramp oil
- Removes suspended solids
- Extends coolant sump life
- Automatic fluid make up
- Separated oils can be sold or reused
- Automatic operation
- Chemical resistant paint
- Compact, self contained



EdjeTech Services

Edjean Technical Services, Inc.
22036 Fairgrounds Road
Wellington, OH 44090
Ph. (800) 242-0525
Fax (877) 806-2400

E-mail: sales@edjetechn.com
Web site: www.edjetechn.com

EdgeTech Services
Tube Mill Coolant Return System

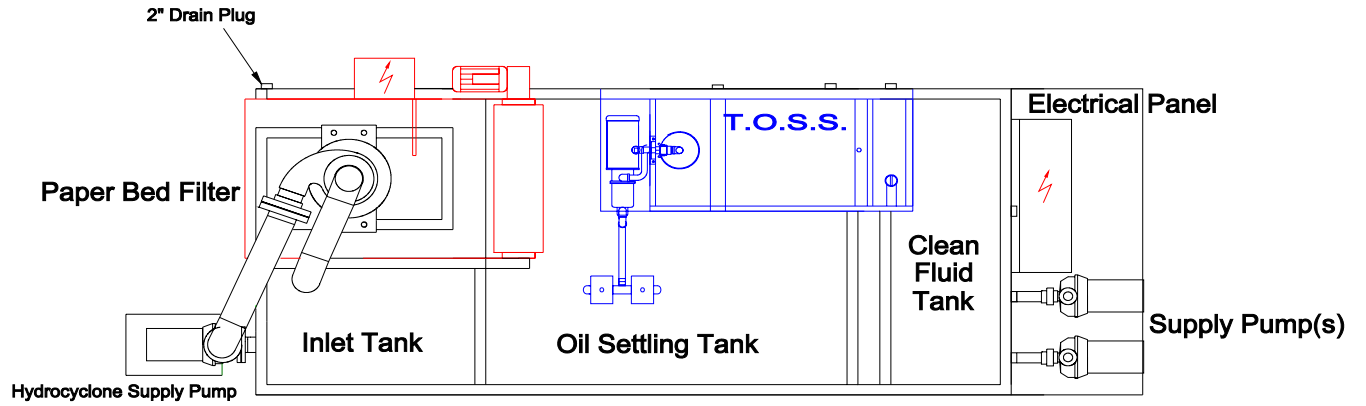

Top View

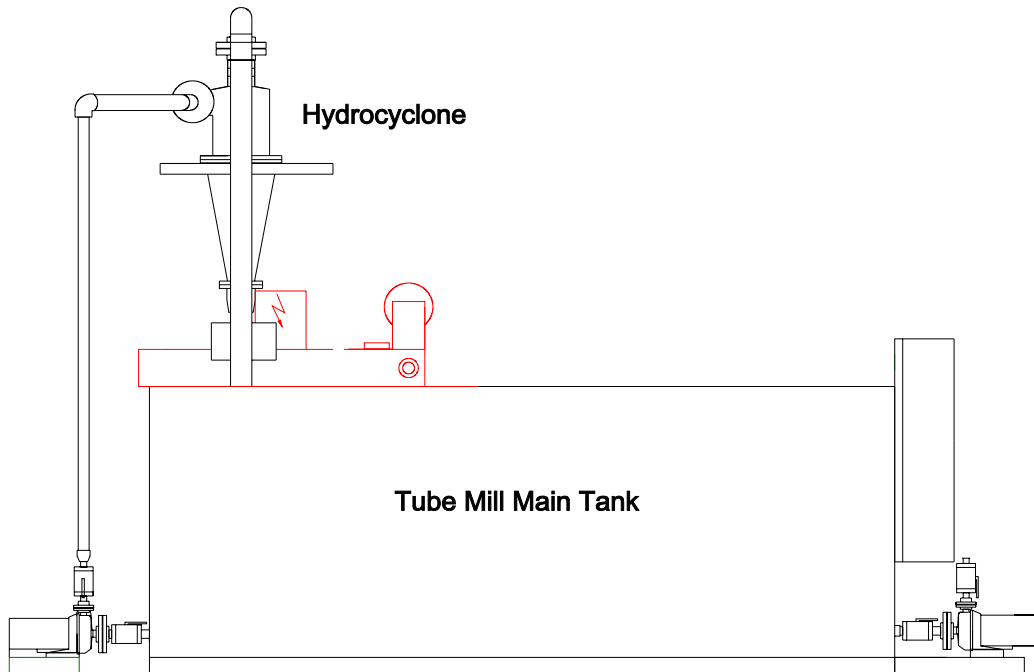

Side View